



# Origin One transportation guide: get to market faster with 3D printed end-use parts.

Flexible production of electrical connectors, adapters, seals and cable management components.





## This solution guide addresses:

- + Why it's time to for transportation OEMs and suppliers to adopt 3D printing for end-use parts.
- + Why companies are using Origin One to manufacture connectors and adapters.
- + Example parts printed on the Stratasys Origin One and recommended materials for transportation applications.
- + Design principles for parts with thin walls, pinholes and high accuracy requirements.



## Manufacturing has a flexibility problem.

3D printing can be an incredibly powerful solution to transportation OEMs' growing problem: As more electrical components are used in vehicles, there is rapidly increasing demand for connectors, adapters, seals or other small parts that can be customized to a variety of needs. At the same time, release cycles are shrinking rapidly, and shipping is becoming more expensive.

3D printing parts offers true manufacturing flexibility for transportation OEMs. Achieve exceptional part quality and accuracy with materials designed for mechanical environments, 3D print parts on demand, reduce time-to-part and save on costs.

## It's time for manufacturers to adopt 3D printing for end-use parts.

OEMs that adopt 3D printing can enable short run production for end-use parts, lower costs and shorten lead times for their customers.

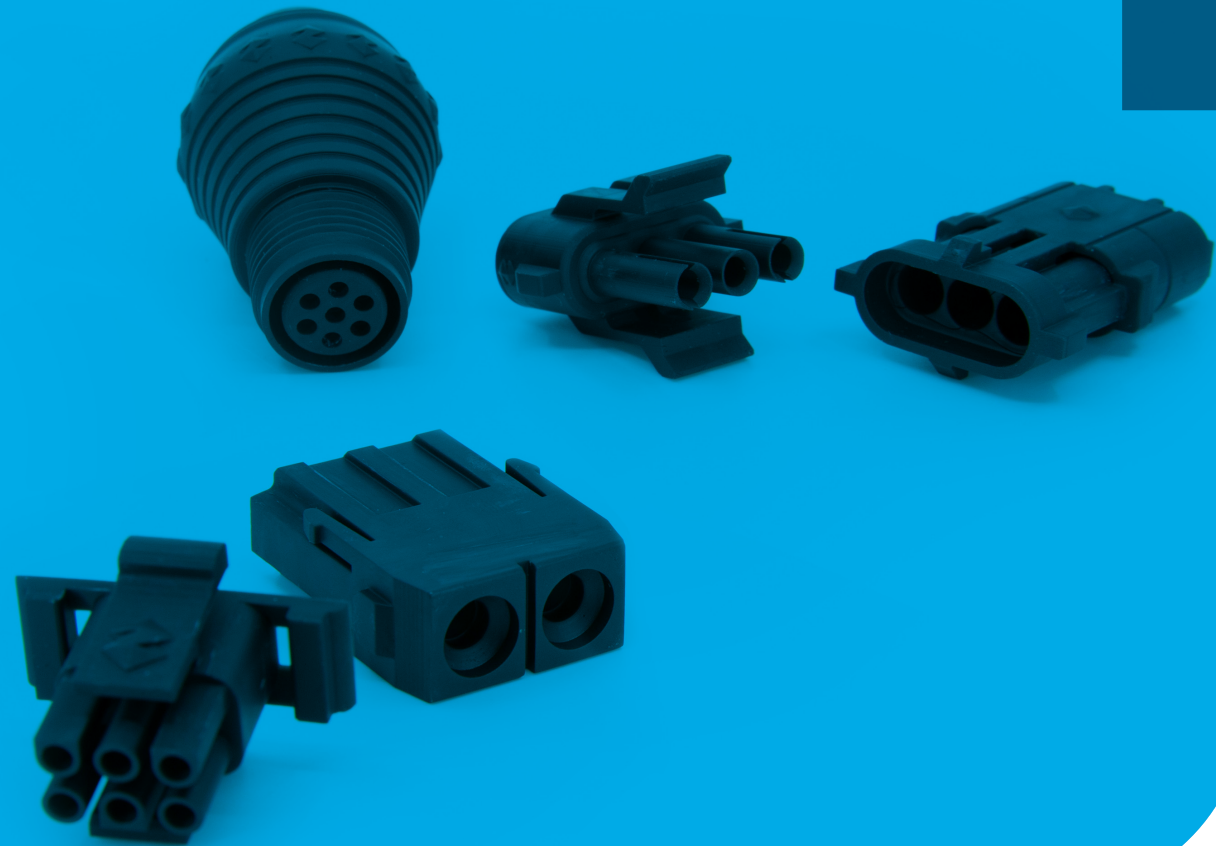

3D printed connector inserts printed in a FST material.

Additive manufacturing offers significant advantages over traditional methods like injection molding and CNC machining.

### Rapid production of end-use parts.

Traditional manufacturing methods are cost and time prohibitive for short-run production and generally have a minimum order quantity for viability. They also do not allow for customized parts without incurring massive tooling costs.

With 3D printing, prototypes are on your desk in hours; end-use parts are available in production quantities in days. Create parts with challenging geometries – such as hinges, clips and snap fits – reliably, quickly and accurately.

### Shorter lead times.

With ongoing supply chain disruptions adding delays to already long lead times, OEMs have been forced to slow their own deliveries.

3D printing enables OEMs to reduce time-to-part and accelerate fulfillment to their customers by reducing shipping and tooling time.

### Lower costs, less waste.

One of the natural benefits of reducing shipping, eliminating tooling and expanding production possibilities is overall lower cost manufacturing.

Additive manufacturing is less wasteful across the board – less shipping, no molds to make, much less or no material discarded and the ability to create parts on demand, which reduces or eliminates inventory storage needs.

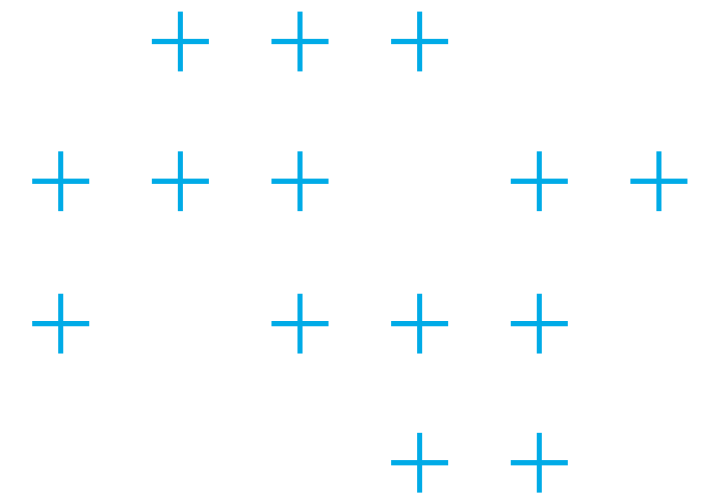

# Production 3D printing is more than just a pipe dream: companies are adapting to the future of manufacturing.

TE Connectivity and InterPRO demonstrate significant reductions in costs and time-to-part that are possible with additive manufacturing, while maintaining – or enhancing – part quality, when compared to traditional manufacturing methods.

## Why Origin One?

### High throughput:

TE Connectivity was able to print 10+ parts per hour.

InterPRO was able to print two 80mm adapters in 2.5 hours.

### Excellent surface quality:

Surface roughness as fine as 0.2  $\mu\text{m Ra}^*$

### High accuracy:

Tolerances as low as 0.001 in / 0.0254 mm\*

### High-HDT and FST materials:

Up to 300°C  
UL 94 V-0

\*Will vary by geometry and material



## TE Connectivity:

Electrical connectors for a helicopter manufacturer.

### Challenge

Find an aerospace-grade material that could be printed with +/- 0.003 in. accuracy, and a 3D printing solution capable of reliably printing the part at a rate exceeding 10 parts per hour - without driving up costs.

### Solution

TE Connectivity designed a new part with Origin One that met all requirements, while keeping part cost low. LOCTITE 3D 3955 HDT280 FST was selected as the material, as it is an FST rated material and can be manufactured with double-digit micron accuracy.

Parts can now be printed in a day instead of weeks, enabling TE Connectivity to offer their first 3D printed aerospace production part, the 369 Series connector housing.

## InterPRO:

Motor adapter for bioreactor client, Distek.

### Challenge

Distek requested that InterPRO Additive Manufacturing create a motor adapter that is compatible between Distek's proprietary bioreactor and their clients' existing motors. The shape needed was impossible to make with injection molding, CNC machining or cast urethane. Distek required a fast turnaround, quick print times and an extensive material selection.

### Solution

Origin One was selected as the printer for its extremely high-quality surface finish. LOCTITE 3D 3843 HDT60 was selected as material for its toughness and machinability.

The Origin One printer can produce two 80mm height adapters in just 2.5 hours with zero tooling costs. InterPRO continues to print multiple SKUs as needed for Distek clients, achieving fast turnaround times and an economic price point on low volume production runs. This allows Distek the manufacturing flexibility to address clients' individual needs in real time, at no additional cost.

 [Learn more](#) about Origin One's material catalog



# A 3D printer made for production: the Stratasys Origin One.

Say yes to more jobs with flexible manufacturing capabilities.

The Origin One is made for flexible manufacturing without inventory or retooling penalties.

Parts have excellent surface quality, high accuracy, repeatability and print in industry-leading times.

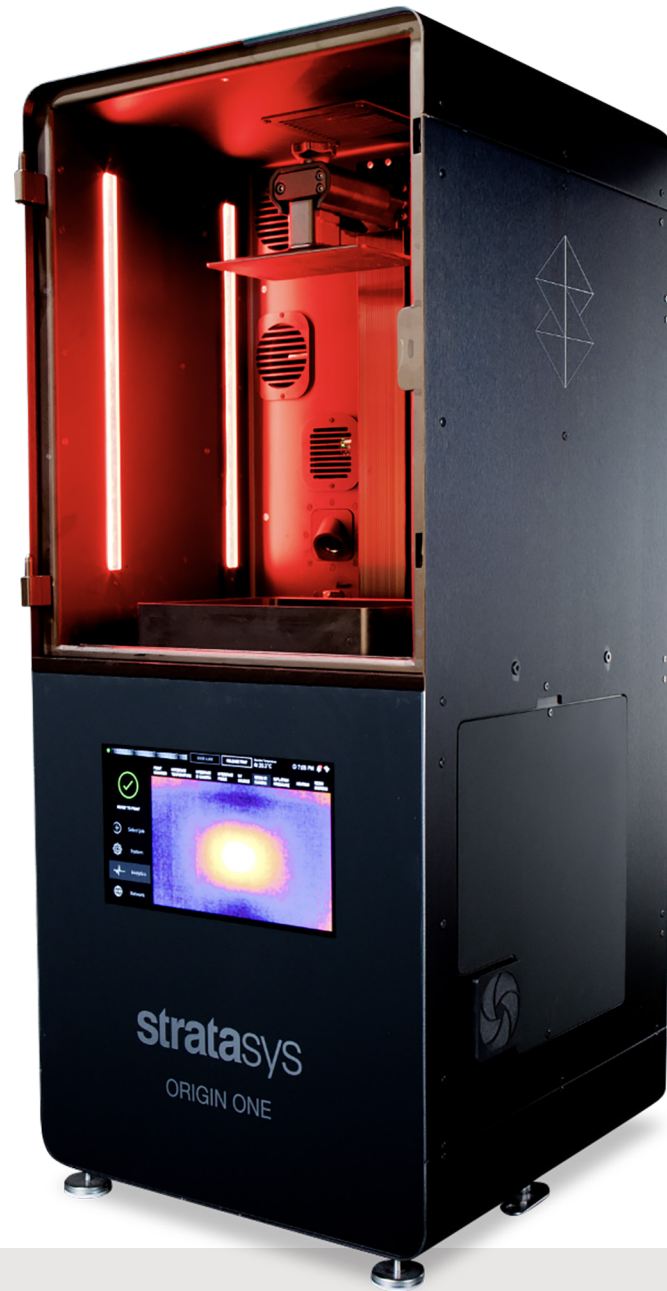

## Excellent surface quality.

P3 precisely orchestrates light, temperature, pull forces and pneumatics to optimize prints for the best possible results. Manufacturers can achieve injection molding part quality and surface finish with incredible accuracy, in a diverse and continuously growing range of high-performance materials.

## Tough, robust prints.

The P3 process produces a high polymerization conversion, unlocking faster print times, extreme geometries and build nesting. This means higher green strength, which reduces cure times and prevents damage during post-processing.

## High throughput, fast print times

The high speed at which 3D printing produces parts can be impactful throughout the product lifecycle. The Origin One's print speeds are fast enough that product designers can often iterate daily on small parts.

## Industry leading accuracy and repeatability.

P3 technology is precise and predictable, which offers high isotropy and repeatability. The Origin One is capable of 100 to 25 micron tolerances (material and geometry dependent) and consistent mechanical properties.

## Expansive material portfolio includes FST, tough and elastomer options.

As 3D printing materials take hold in manufacturing, the variety of photopolymers has exploded in breadth and functionality. Current offerings include ABS analogs, elastomers and options that pass FST and vertical burn tests.

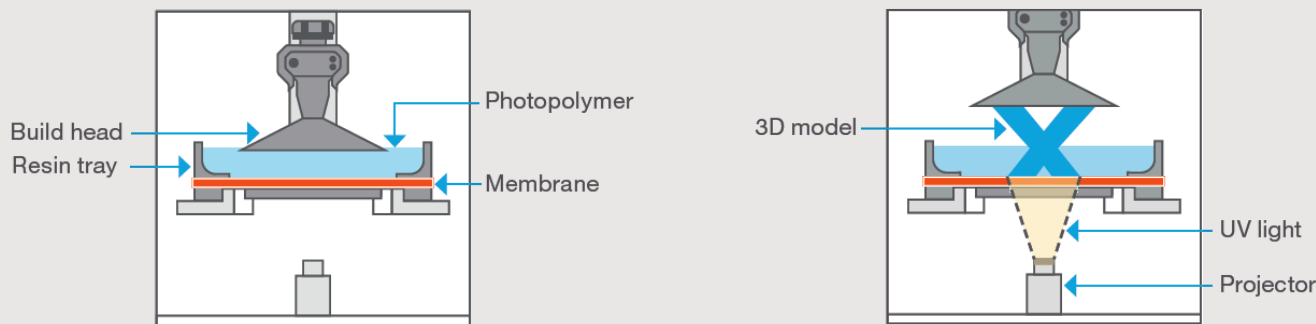

### Programmable PhotoPolymerization P3™

P3 extends DLP printing capabilities with a combination of several tightly controlled, programmable steps that support production applications with photopolymers.

 [Request](#) a free part sample

# High-mix, low-volume production of automotive end-use parts.

The Stratasys Origin One can print a wide variety of materials, which makes it perfect for manufacturing a diverse range of small- to medium-sized parts.

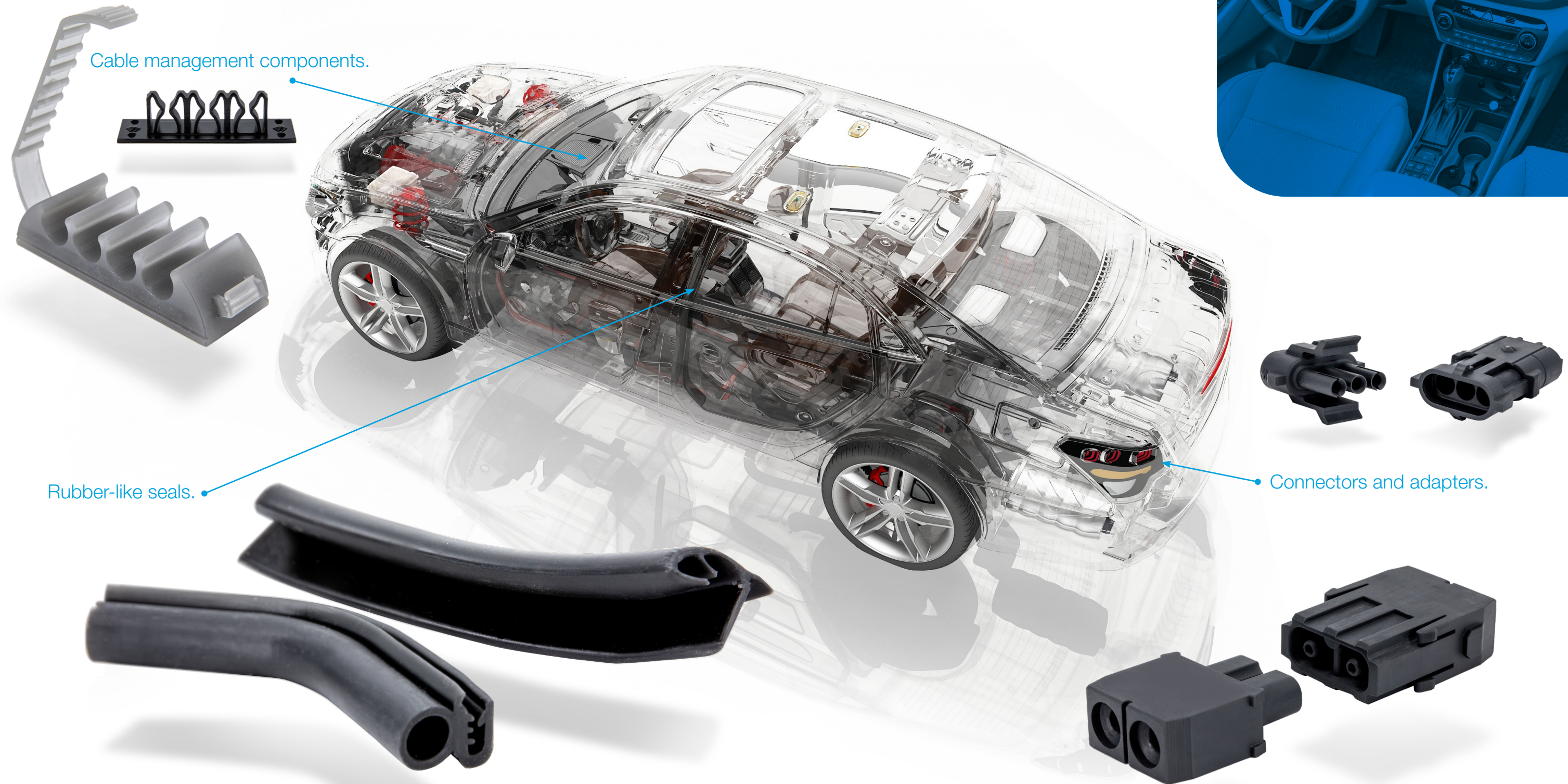

# Electrical connectors with excellent surface quality that pass vertical burn and FST standards

Parts made on the Origin One have a class A surface finish and are accurate and repeatable, ensuring a consistent fit.

These parts were printed together in LOCTITE 3D 3955 HDT280 FST, a highly viscous material that is halogen-free, flame retardant, high modulus and able to withstand temperatures up to 300°C.

Dozens to hundreds of these parts can be printed per day, for much lower cost than injection molded alternatives up to counts of several thousands, and with greater geometric possibilities.



Parts/print: 33  
Volume per part: 12.7 cc  
Print time: 1.45 hrs  
Cost per part: \$6.33  
IM mold cost: \$6470.00

Parts/print: 33  
Volume per part: 11.8 cc  
Print time: 1.4 hrs  
Cost per part: \$5.92  
IM mold cost: \$8,650.00



Parts/print: 10  
Volume per part: 31.9 cc  
Print time: 2 hrs  
Cost per part: \$16.7  
IM mold cost: \$10,915.00  
IM part cost only: \$16.94

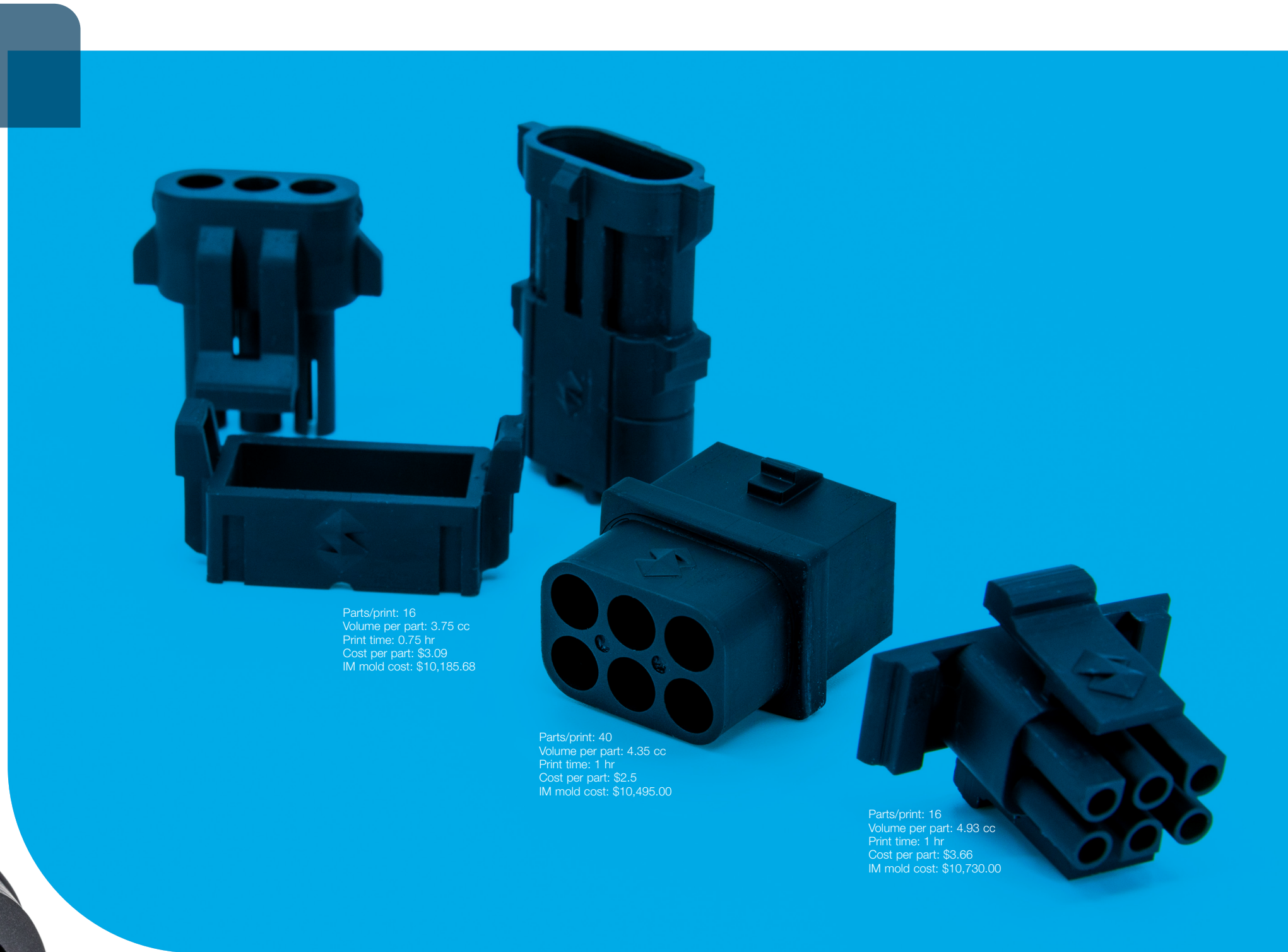

Parts/print: 16  
Volume per part: 3.75 cc  
Print time: 0.75 hr  
Cost per part: \$3.09  
IM mold cost: \$10,185.68

Parts/print: 40  
Volume per part: 4.35 cc  
Print time: 1 hr  
Cost per part: \$2.5  
IM mold cost: \$10,495.00

Parts/print: 16  
Volume per part: 4.93 cc  
Print time: 1 hr  
Cost per part: \$3.66  
IM mold cost: \$10,730.00

\*Part costs estimated based on single build of listed number of parts. IM mold costs derived from 2022 US manufacturing and prototyping service bureau estimates.

## Flexible rubber-like seals.

Elastomers can be printed in a variety of geometries on the Origin One, allowing OEMs to quickly manufacture rubber-like seals such as gaskets, weatherstripping and more.

These seals were printed in Loctite IND402, which is a single component elastomer with high resilience and rebound. This material has excellent tensile strength and does not require thermal post-processing. It is comparable to TPUs with a Shore A hardness of 75.



 [Learn more](#) about Loctite's high rebound material



Material: Loctite IND402  
Parts/print: 12  
Volume per part: 41.20  
Print time: 12.7 hr  
Cost per part: \$20.45



## Tough and durable cable management solutions.

The Origin One is an industry leader for printing challenging overhangs and small features, while maintaining excellent surface finish. This is due to the low separation forces of P3 technology, which ensure that holes, loops and clips are accurate to the original design and allow for more challenging geometries to print successfully.

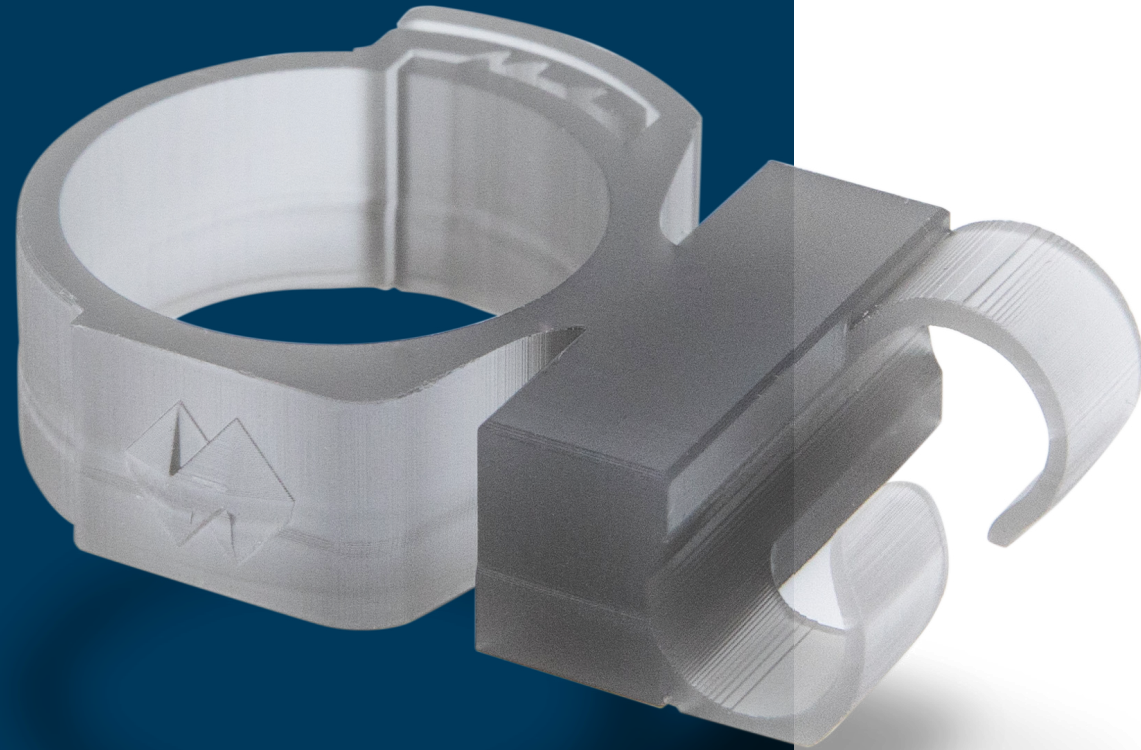

Material:  
LOCTITE 3D  
3172 HDT50  
High Impact Clear

Parts/print:  
10

Volume per part:  
6.6 cc

Print time:  
57 minutes

Cost per part:  
\$3.50



Material: SOMOS® QuickGen 500  
Parts/print: 10  
Volume per part: 18.2 cc  
Print time: 1h 52m  
Cost per part: \$5.28

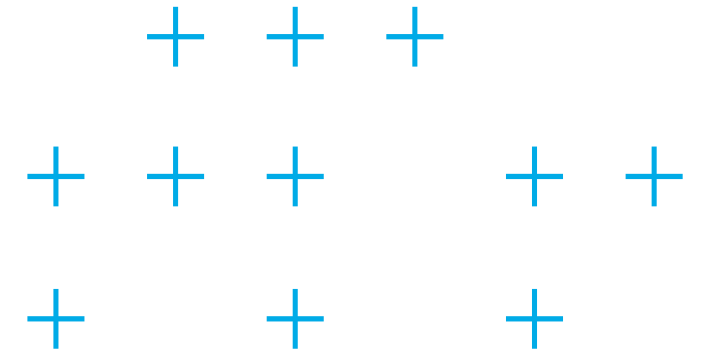

Material: LOCTITE 3D 3172  
Parts/print: 6  
Volume per part: 34.1 cc  
Print time: 5h  
Cost per part: \$14.79



Material: Ultracur3D® ST45  
Parts/print: 7  
Volume per part: 13.5cc  
Print time: 58 minutes  
Cost per part: \$7.33

 [Learn more](#) about Origin One's material catalog

# Design for Additive Manufacturing: tips and tricks.

How to minimize supports when printing fine-detailed parts on the Origin One.

For the best print quality and efficient use of materials, consider orientation to determine what your part's support requirements, packing efficiency and throughput will be.

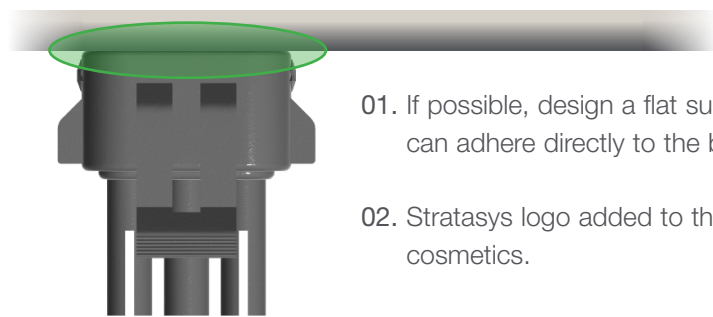

- 01. If possible, design a flat surface that can adhere directly to the build plate.
- 02. Stratasys logo added to the side for cosmetics.
- 03. Orient your print in a way that eliminates overhangs and minimizes supports.

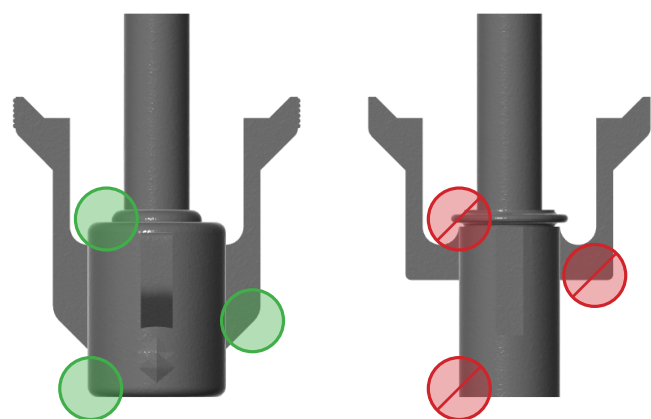

- 04. Fillet is added to the platform-connecting surface, which aids in part removal.
- 05. Taper downward-facing flat surfaces. This ensures they will not require supports.

01

02

03

04

05

06

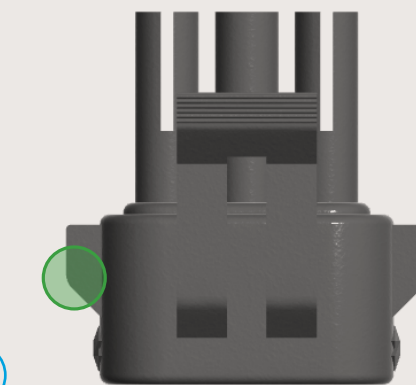

06. Snap nub on side is tapered to be self-supporting.

07

07. Make sure bridges span less than 10mm to avoid risk of warpage.

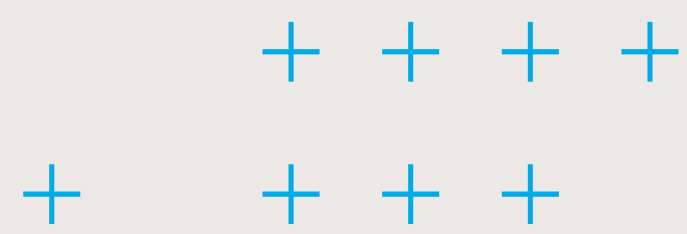
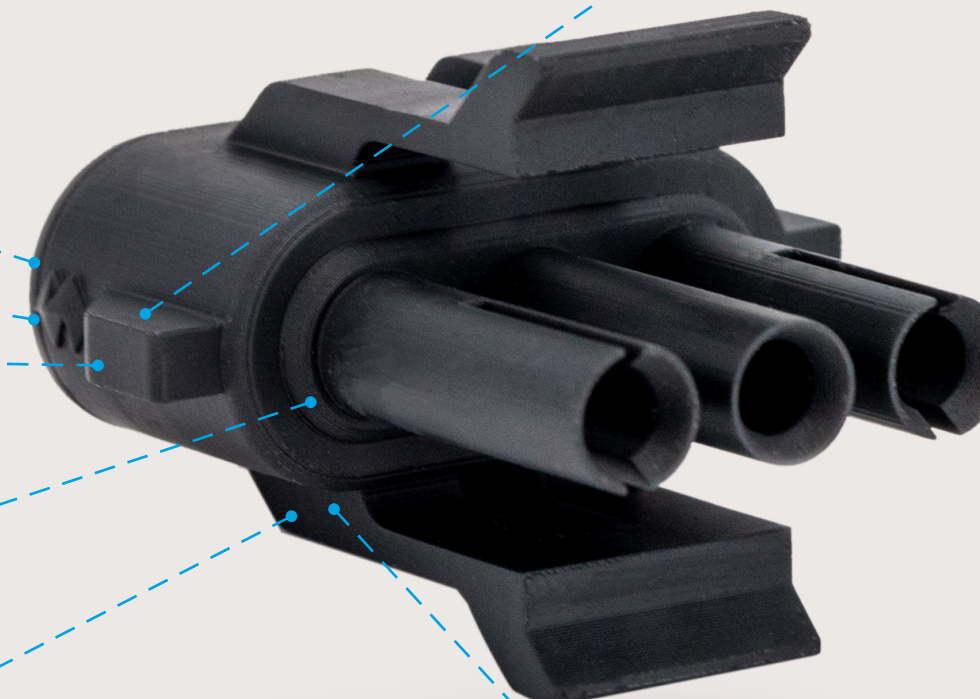

## Before and after: DfAM at work.

Converting an existing design to be compatible with vat polymerization 3D printing.

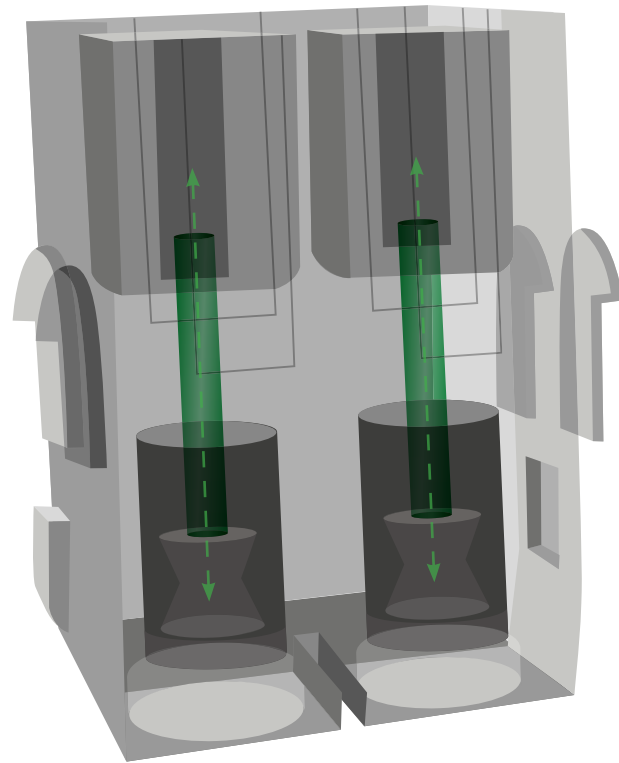

01. Add small through-holes between top and bottom blind holes for easier cleaning

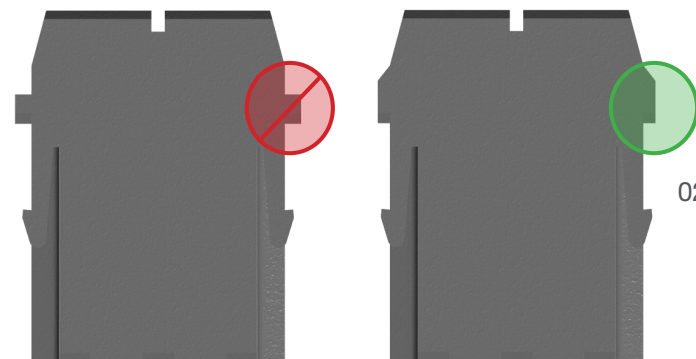

02. Original snap feature was replaced with a male nub feature for enhanced functionality.

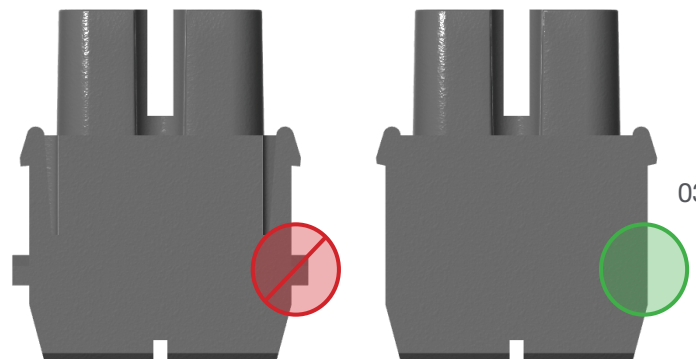

03. Removed the large overhang in snap feature that would require supports.

For the best print quality of small, fine details with photopolymer materials:

- + Add chamfers to surfaces that are in contact with the build platform, especially if they are flat. This allows for better aesthetics and easier removal of the part.
- + Avoid blind holes, especially those that are small and deep, when possible.
- + Always consider elongation properties of your chosen material when designing snap features.

# Material options for the Stratasys Origin One.

A variety of photopolymers, including heat resistant, tough, durable, and more.

It takes an ecosystem to transform an industry. Stratasys works with leading chemical companies to co-develop innovative photopolymers in several categories to unlock end-use applications in 3D printing.

## Heat-Resistant

Materials for application-specific requirements, such as flame smoke and toxicity, HDT or mold durability.

## General Purpose

Fast-printing materials for end-use applications requiring cosmetic surfaces, fine features and high accuracy.

## Tough

Impact-resistant resins for functional applications that need to perform under stress and high-load conditions.

## Elastomers

Resilient, high-resolution elastomers for applications requiring excellent tear strength or rebound performance.

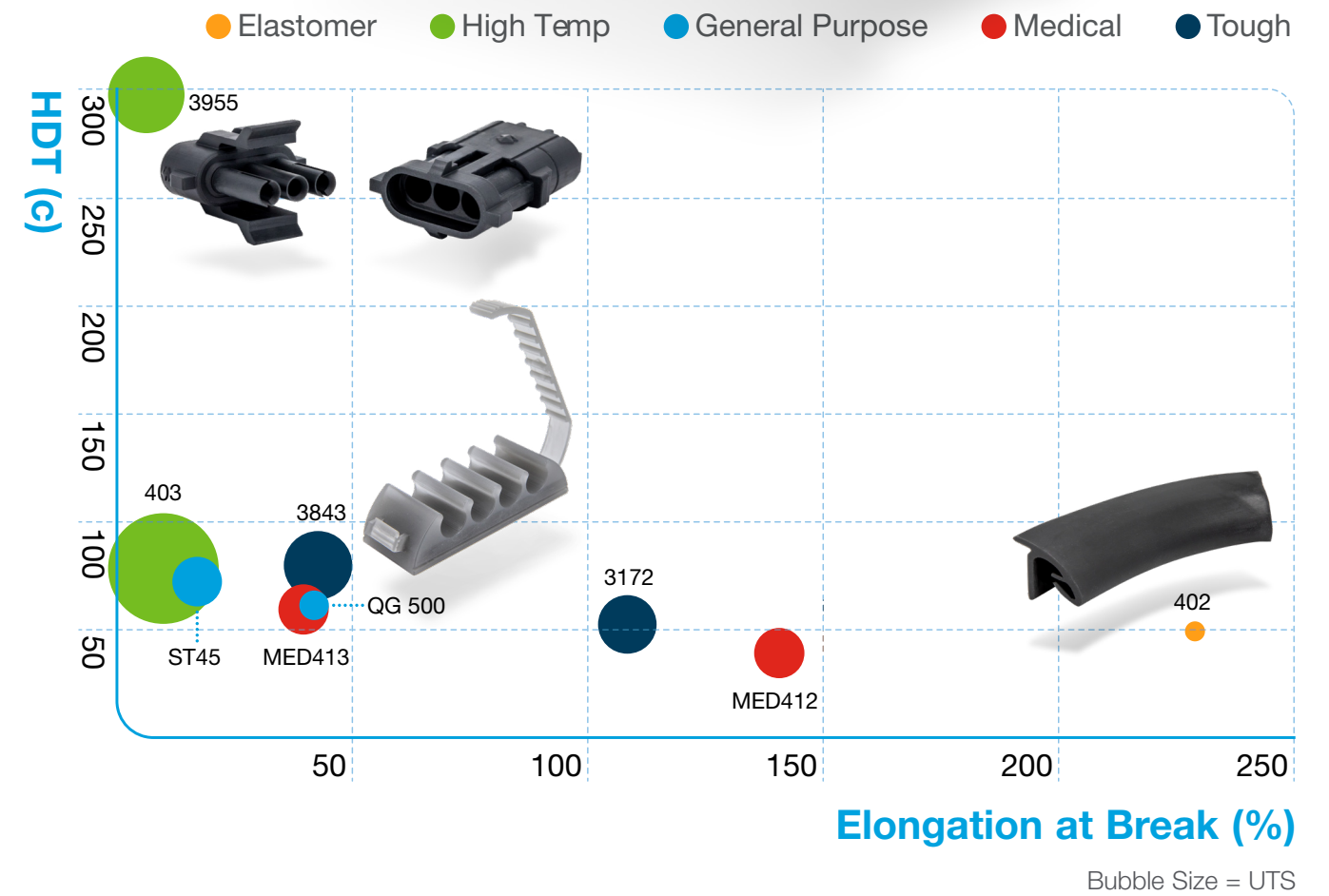
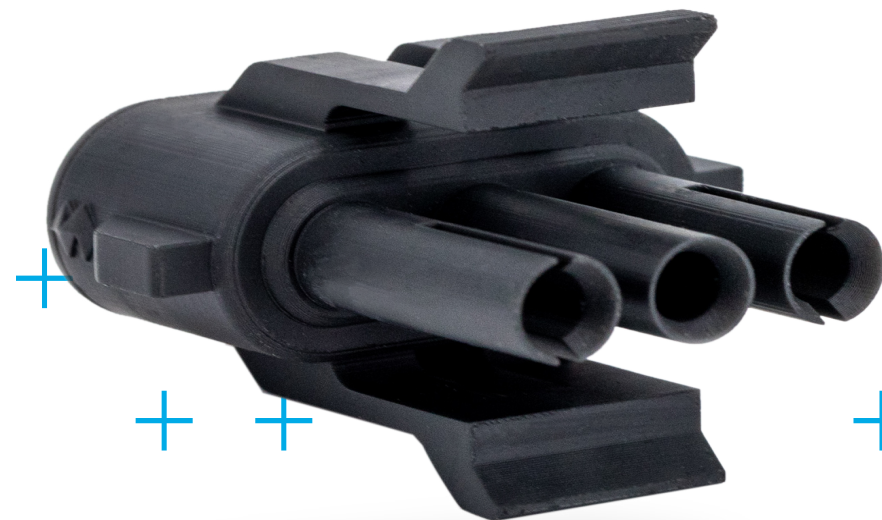

# Increase manufacturing flexibility

From consulting to on-demand parts, Stratasys offers a wide range of additive manufacturing services at every stage of the process. If you want to use more demanding additive manufacturing technologies but don't have the space or budget for it, Stratasys can provide a team of experts to support you at every stage of the product development and manufacturing process.

## Decrease time to part, increase ROI.

Find a local reseller today at [stratasys.com](http://stratasys.com)

Request a free  
sample part



### Stratasys Headquarters

7665 Commerce Way,  
Eden Prairie, MN 55344  
+1 800 801 6491 (US Toll Free)  
+1 952 937-3000 (Intl)  
+1 952 937-0070 (Fax)

1 Holtzman St., Science Park,  
PO Box 2496  
Rehovot 76124, Israel  
+972 74 745 4000  
+972 74 745 5000 (Fax)

[stratasys.com](http://stratasys.com)

ISO 9001:2015 Certified

© 2022 Stratasys Ltd. All rights reserved. Stratasys, Stratasys signet, Origin and P3 are trademarks or registered trademarks of Stratasys Ltd. and/or its subsidiaries or affiliates and may be registered in certain jurisdictions. All other trademarks belong to their respective owners. Product specifications subject to change without notice. SG\_P3\_ORIGIN\_TRANSPORTATION\_GUIDE\_0322a

