



## Additive Manufactured Production-Grade Saddle SAM:

Maximum comfort at top riding performance achieved with the H350™, leveraging SAF technology



# Additive Manufactured Production-Grade Saddle SAM:

Maximum comfort at top riding performance achieved with the H350™, leveraging SAF technology

## Abstract

The objective of this whitepaper is to evaluate both lab and field results for an additive manufactured saddle created by DQBD. DQBD is an innovation-driven design and development firm based out of Germany. To produce the semi-rigid 3D printed saddle spine, DQBD utilized High Yield PA11 polymer powder and SAF™ technology. This saddle is the first of its kind which uses additive manufacturing for load-bearing structures. In order to customize the experience for each rider, the saddle's spine is individually calculated. This creates a tailored fit and ensures the best possible connection with the bicycle. Due to the nature of cycling on and off road, the saddle must exhibit high impact strength and ductility so High Yield PA11 is the optimal choice.



### Goal of study

DQBD aimed to verify their Finite Element simulations through load and impact tests in both the lab and field. They needed to ensure that they complied with relevant standards while combining comfort with high power efficiency.

### The part

The 3D printed spine is created according to a rider's specific pressure points. In order to properly match the saddle to a rider's anatomy, an underlying set of geometry is manipulated. This includes the rider's sit bone position, weight and usage characteristics. With this data as a reference, SAF technology facilitates the creation of a personalized saddle spine with extreme accuracy.

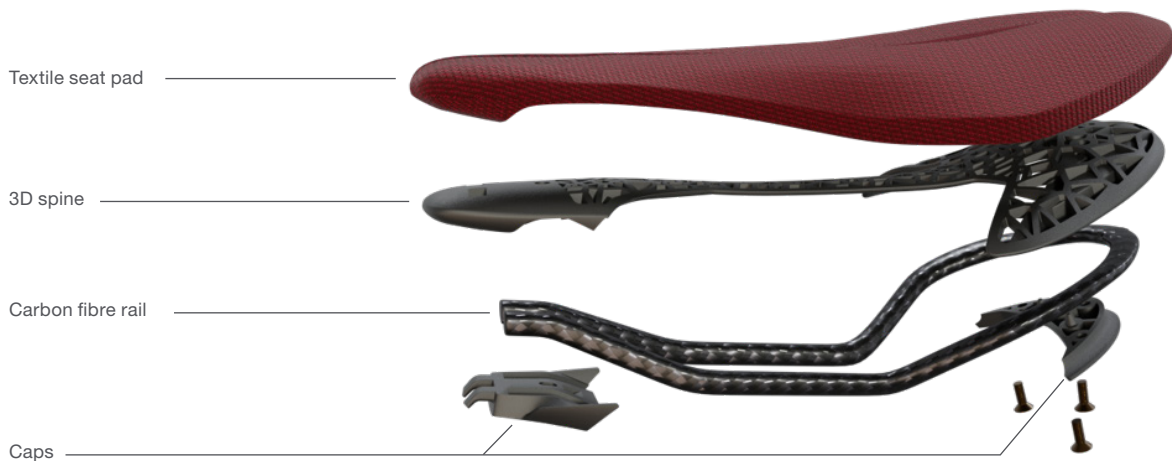

Within the saddle, the 3D spine holds the textile seat pad in place. The spine has areas that are sturdy while other areas are flexible. Central and lateral strategic zones provide a highly efficient energy transmission from the rider to the bike. By design, the saddle offers controlled adaption where needed. The connected nose and rear end of the 3D spine contain free cutouts. This improves the deflection of saddle cushioning and increases comfort.

# Testing

DQBD performed extensive lab and field testing to represent typical use cases so they could understand exactly how the saddle will perform.

In the lab, they conducted static and dynamic load tests on saddle prototypes and a variety of seat pad fabrics. These tests confirmed structural integrity during use.

Outside, their prototype saddles underwent qualified road testing which included thousands of kilometers, both on and off the road.



# Testing

## Saddle static strength test

According to EN 14781<sup>1</sup>, this test confirms that the saddle cover doesn't detach from the framework of the saddle.

Additionally, there shouldn't be any cracking or permanent distortion of the saddle assembly.

### Test method

In order to perform this test, the saddle must be attached to an appropriate fixture, such as a seat-pillar. The clamps must be tightened to the torque determined by the bicycle's manufacturer.

A force of 400 N is applied under the rear and the nose of the saddle cover. By pulling upwards on both the front and back of the saddle, this validates that the force is not applied to any other area of the saddle's framework.

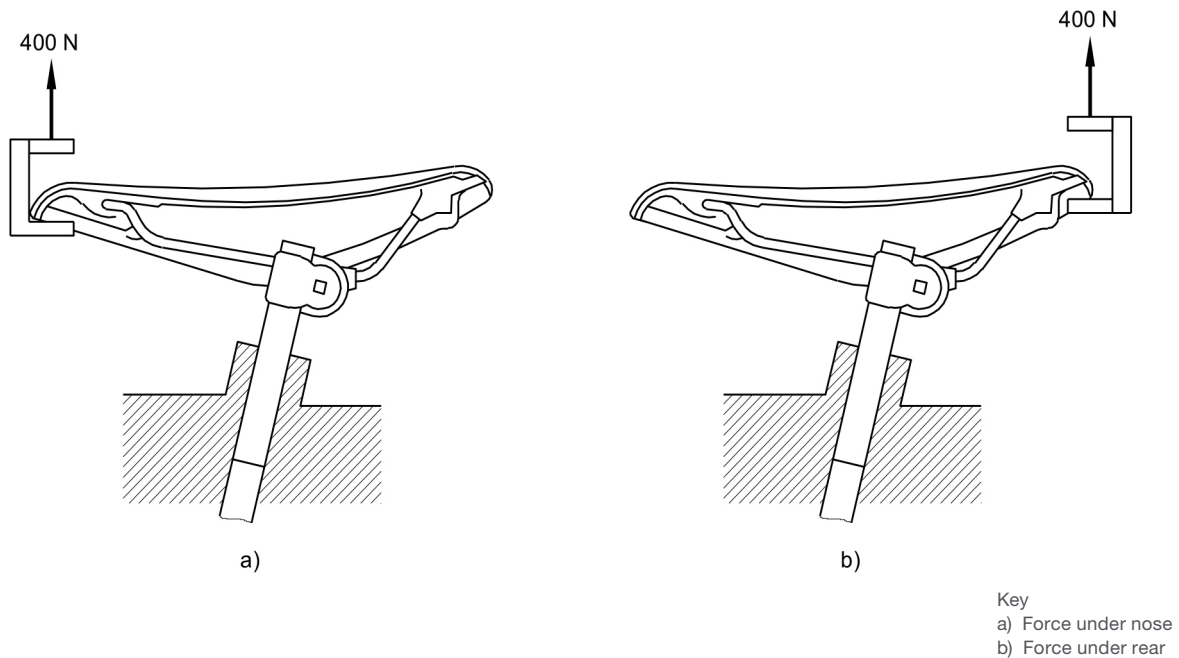

### Test results

As force was applied, the saddle was observed for any damage, such as parts suddenly breaking off or splitting. This did not occur during the test, so the saddle was then examined for any cracks or visible tears. When no damage was discovered, DQBD reattached the saddle to the bicycle and confirmed that the saddle performed properly.

<sup>1</sup> EUROPEAN COMMITTEE FOR STANDARDIZATION (2005). Racing bicycles - Safety requirements and test methods. EUROPEAN STANDARD EN 14781, 68-69.

# Testing

## Saddle and seat-pillar clamp fatigue test

Also, per EN 14781, the seat-pillar may cause the saddle to fail so the saddle and seat-pillar must be evaluated together.

When tested, there shouldn't be any fractures or cracks in the seat-pillar or saddle. The saddle clamp should remain tight.

### Test method

The seat-pillar is positioned to its lowest point in a firm mount, similar to the one on the bicycle. It should be at an axis of  $73^\circ$  to the horizontal.

The saddle is placed on the seat-pillar and aligned so its upper surface is horizontal. The saddle should be located at its highest rearward position in the clamp.

The clamp is tightened to the torque determined by the bicycle's manufacturer.

A repeated, vertically downward force of 1,000 N is applied for 200,000 cycles. The test frequency shouldn't surpass 4 Hz.

### Test results

In order to assess the saddle's performance, the first and last cycles of the test were compared and evaluated to see if there was any change in the saddle's reaction to the applied force, or level of deflection. As no visual damage was determined, DQBD repositioned the saddle on the bicycle to test its performance. The saddle successfully passed this examination and maintained the same quality it had possessed before the test.

It is important to note that the structural parts in the saddle design are all quite accessible and easy to inspect, so there was no need to disassemble the saddle to check for damage.

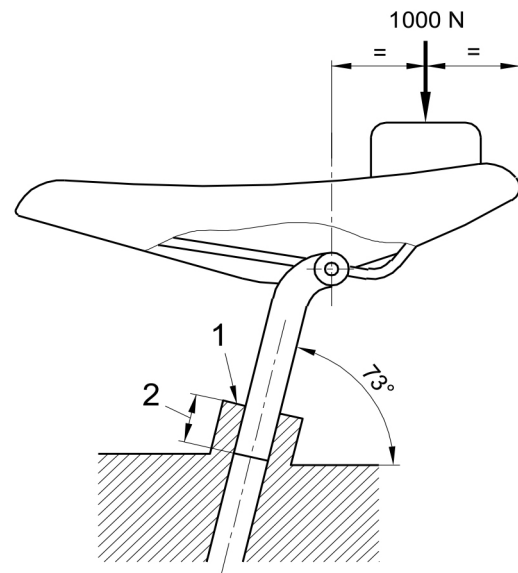

Key  
1 Rigid mount  
2 Minimum insertion depth

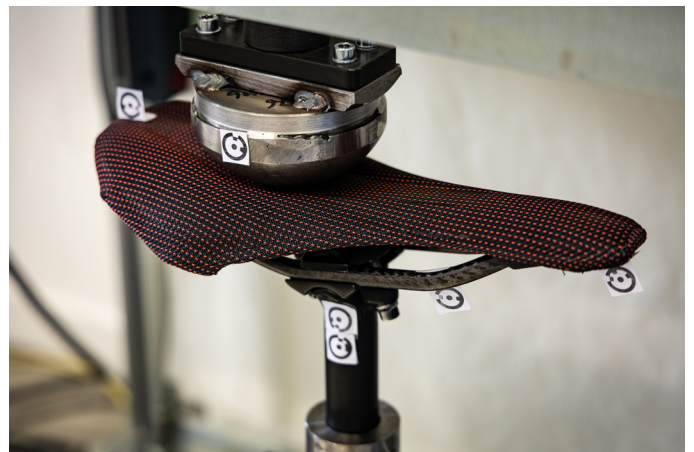

# Testing

## Internal maximum deflection test

DQBD developed their own internal evaluation based on JIS D 9431<sup>2</sup>.

### Test method

The saddle is fixed with its seat surface positioned horizontally. An 8 kg (17 lbs.) weight is dropped on the saddle from a height of 600 mm (23 in.). The total impact energy is 47 Joule (J). No part of the saddle should break during this test. The goal is to remain under 21 mm (0.8 in.) of deflection. If this amount is exceeded, chances are that the saddle will hit the clamp which is extremely uncomfortable for the rider. The rails may also break which would be detrimental to the bicycle.

### Test results

This graph depicts the movement of the impactor. The vertical white line represents the point of the saddle's maximum deflection. Maximum deflection was 17 mm (0.7 in.), which is under the limit of 21 mm (0.8 in.). This allows shocks to be absorbed while preventing the rider from hitting the seat clamp, which is the ideal outcome.

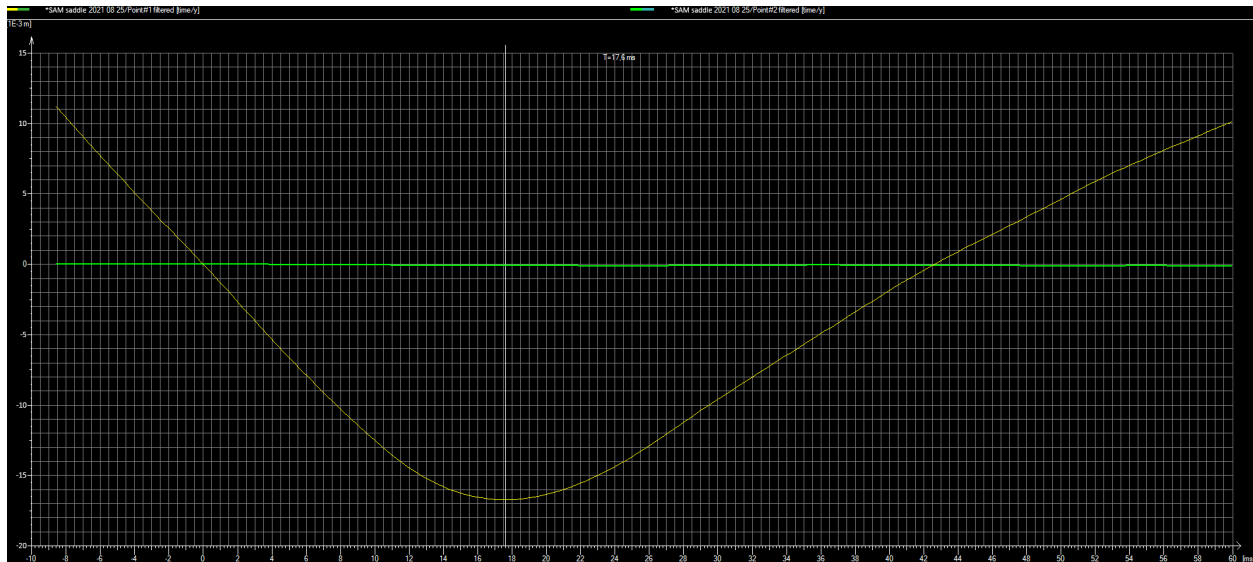

<sup>2</sup> Japanese Standards' Association (1989). *Saddles for Bicycles*. JAPANESE INDUSTRIAL STANDARD JIS D9431, 3.

# Testing

## Climate chamber testing

To prepare the saddle for international shipping and usage in tropical conditions, the saddle is placed in an ageing test climate chamber. The saddle must withstand temperatures higher than 70 °C (158 °F) at 70% relative humidity for a duration of three weeks.

## Test results

The saddle passed this test which confirms that the material will not degrade in these circumstances. There was no significant change in terms of the saddle's performance, structure or fatigue. Additionally, the saddle didn't fracture or have significant shrinkage as a result of these extreme conditions.





# Testing



## Field testing

Over the course of a year, the additive manufactured saddle was ridden for more than 5,000 kilometers (over 3,000 miles). The saddle encountered various types of weather, with temperatures ranging between 5-55 °C (41-131 °F). The riding conditions included dusty areas, tarmac, gravel, wet roads and off-roading. Substantial stress was placed on the saddle since the riding was not performed on continuously flat surfaces. This was exacerbated through occasional mountain bike usage (MTB) by a rider who weighs 80 kg (176 lbs.). The saddle was also tested by other riders, so it had to properly support varying body sizes.

## Test results

After a full year of testing, the saddle proved to offer a unique blend of high performance and extraordinary comfort. This is proven through the saddle's ability to successfully withstand fluctuating weather and outdoor conditions. On bumpy and uneven roads, the zones of flex, together with the fabric seat pad, achieved remarkable shock absorption and equal pressure distribution across the entire contact area. In comparison to other saddles, riders reported less pain and fatigue. This increased the length of their rides and made the experience more enjoyable.

At the end of the testing phase, the saddle components were inspected. There were no signs of deterioration and integral properties remained intact.



# Conclusion

The additive manufactured saddle withstood all lab and field testing and passed the established standards. Based on these positive results, the saddle is cleared for production and field usage. Due to the precision and impact resistance of the H350 3D printed spine, the saddle can absorb low to hard impact, load changes and varying road conditions. SAF technology provides DQBD with complete freedom of design, allowing them to create a product personalized for each rider.



## Stratasys Headquarters

7665 Commerce Way,  
Eden Prairie, MN 55344  
+1 800 801 6491 (US Toll Free)  
+1 952 937-3000 (Intl)  
+1 952 937-0070 (Fax)

[stratasys.com](https://stratasys.com)

ISO 9001:2015 Certified

1 Holtzman St., Science Park,  
PO Box 2496  
Rehovot 76124, Israel  
+972 74 745 4000  
+972 74 745 5000 (Fax)

